

ICE 8 RF Vibratory Hammer

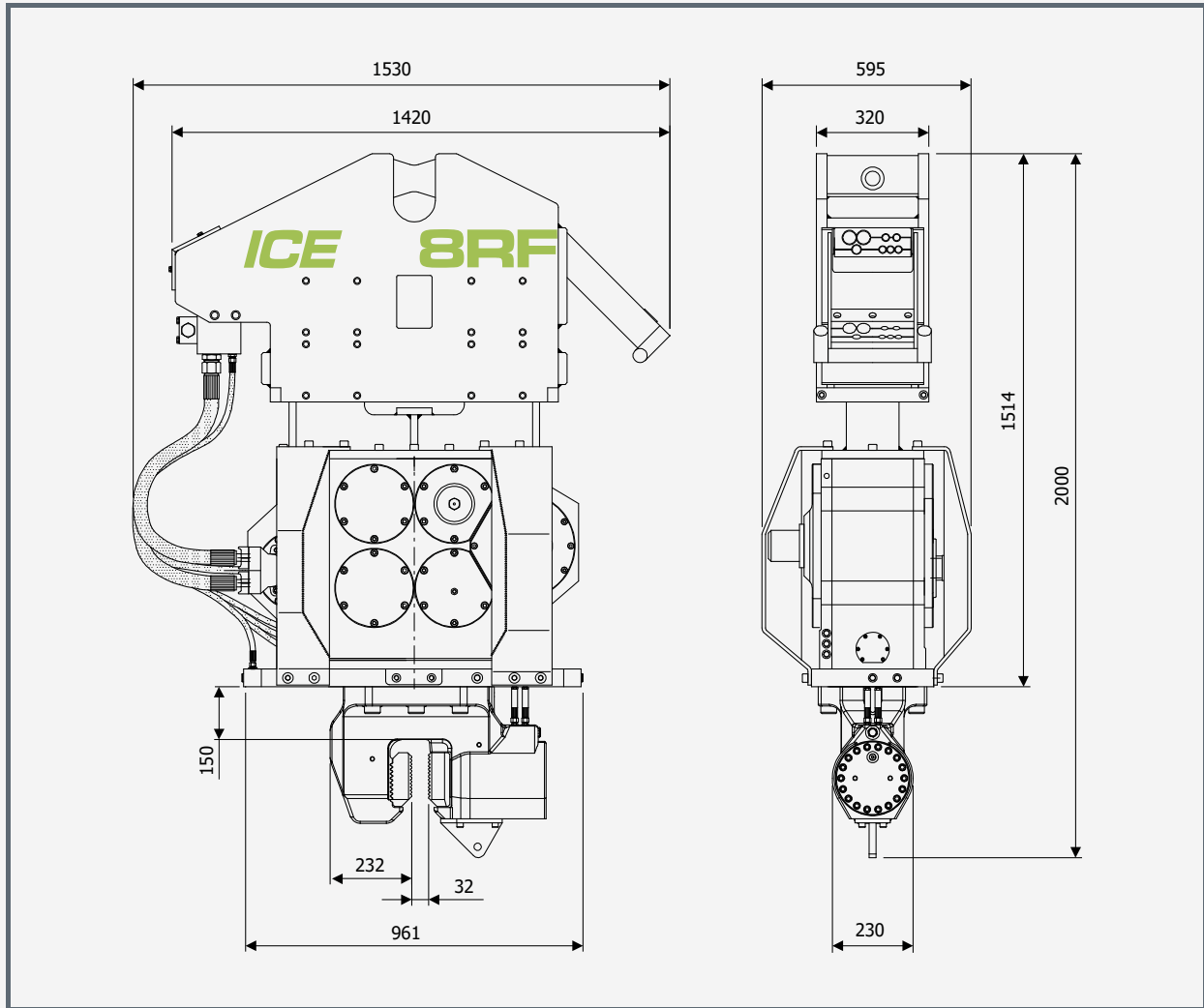

Specifications		8RF	
Eccentric moment	0-7.5	kgm	
Max. centrifugal force	0-435	kN	
Max. frequency	2300	rpm	
Max. amplitude excluding 60TU	15.2	mm	
Max. amplitude including 60TU	12.1	mm	
Max. static line-pull	120	kN	
Max. operating pressure	350	bar	
Max. oil flow	185	l/min	
Forced lubrication	yes		
Dynamic weight excluding 60TU	985	kg	
Dynamic weight including 60TU	1235	kg	
Total weight excluding 60TU & hoses	1515	kg	
		Clamps:	
		Sheet pile clamp	60TU
		Transport weight per piece	250 kg
		Powerpack:	
		Model	200 series
		Hose set:	
		Length	30 m
		Transport weight (±)	325 kg

ICE 200 PP Hydraulic Power Pack

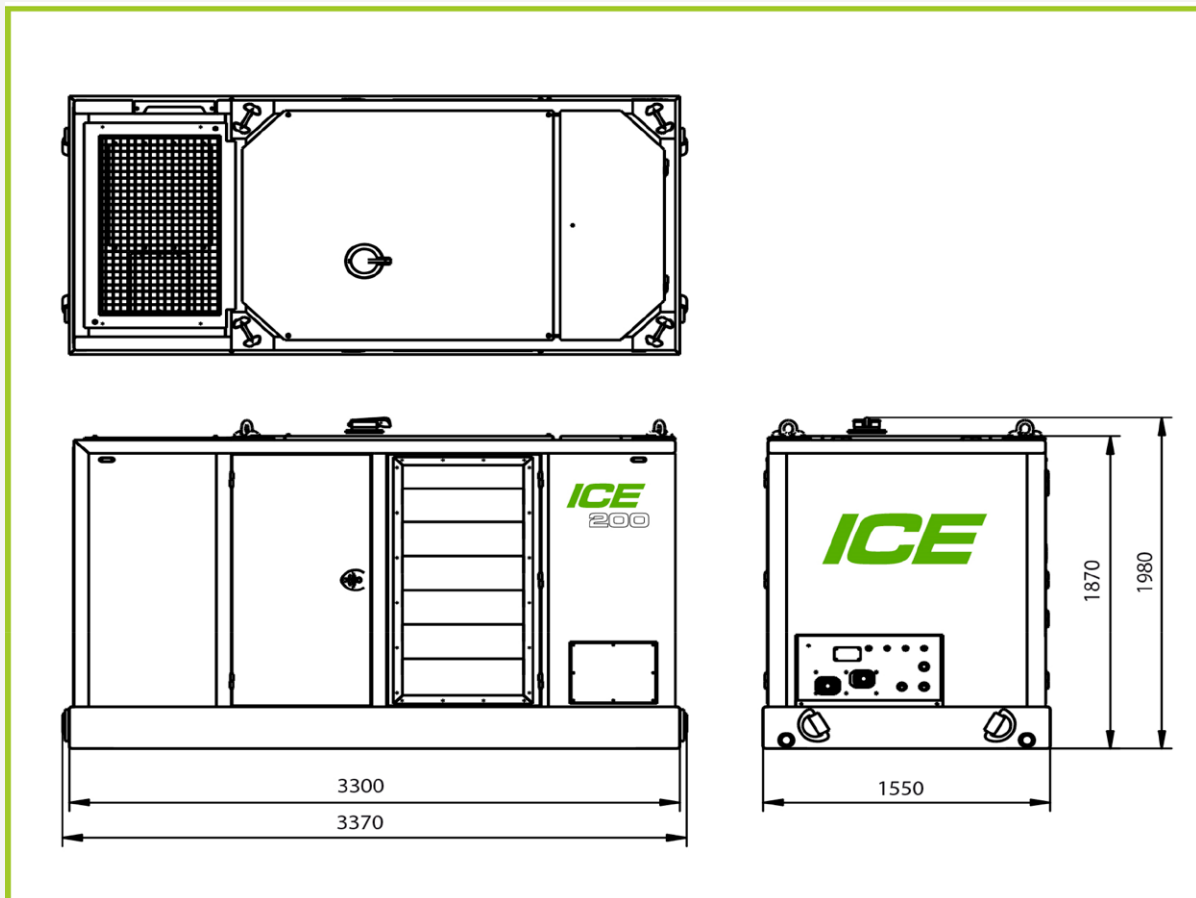

Specifications :	ICE 200 STAGE V	
Diesel Engine	Volvo TAD 582 VE	
Max. theoretical power	160/218	kW/HP
Max. frequency	2300	rpm
Max. operating pressure	350	bar
Hydraulic pump	Parker	
Max. oil flow	211	L/min
Diesel oil	490	L
DEF (AdBlue) capacity	25	L
Hydraulic oil	540	L
Weight without fuel	3900	kg
Weight filled up	4350	kg

ICE 60 TU Universal Clamp

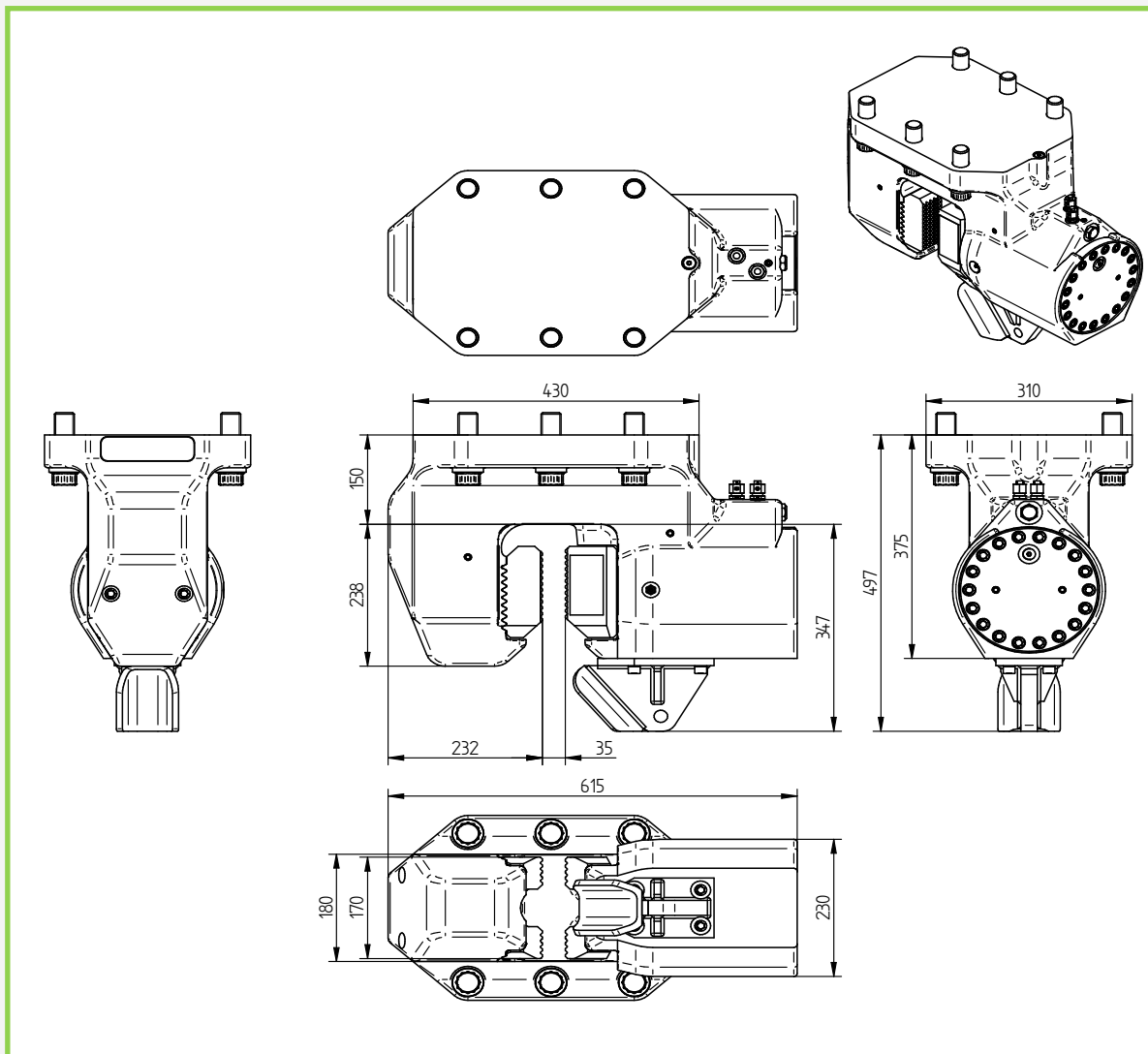

Specifications :	ICE 60TU	
Sheet pile clamp		
Clamping force	600	kN
Max. operating press.	320	bar
Max. clamp open press.	180	bar
Weight	250	kg