

## ICE 6RFB *Vibratory Hammer*

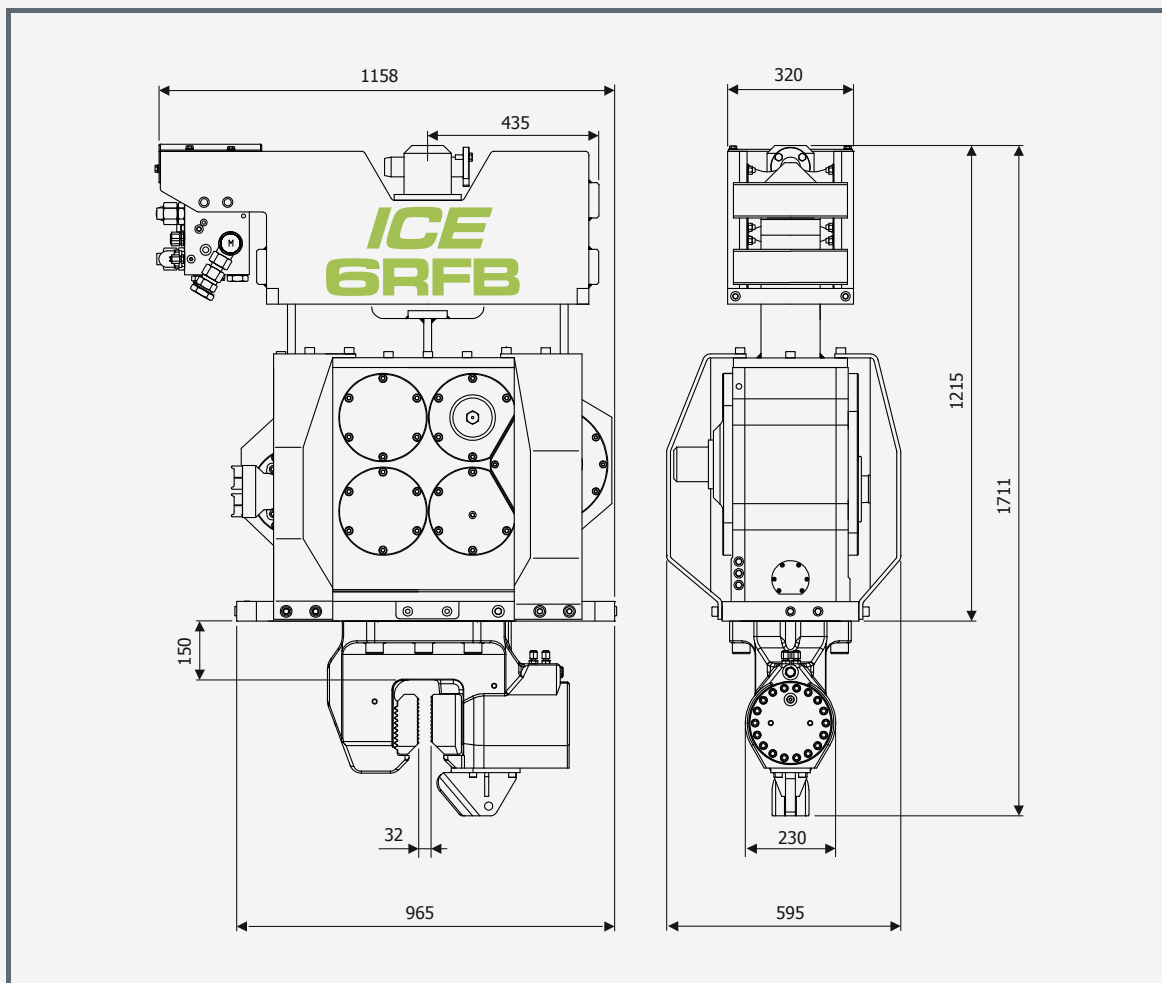

Specifications		6RFB	
Eccentric moment	0 – 6.5	kgm	
Max. centrifugal force	0 – 377	kN	
Max. frequency	2300	rpm	
Max. amplitude excluding 60TU	13.5	mm	
Max. amplitude including 60TU	10.7	mm	
Max. static line-pull	120	kN	
Max. hydraulic power	81/110	kW/HP	
Max. operating pressure	350	bar	
Max. oil flow	138	l/min	
Forced lubrication	yes		
Dynamic weight excluding 60TU	960	kg	
Dynamic weight including 60TU	1210	kg	
Total weight including 60TU	1490	kg	
		<b>Clamps:</b>	
		Sheet pile clamp	60TU
		Transport weight per piece	250 kg