

TWF TIEFBAUTECHNIK

Sales | Rental | Leasing



XL-BOX TYPE 690

www.twf-tiefbautechnik.de

www.twf.at

OPERATING MANUAL

► TWF - XL-BOX Type 690

Contents

General instructions	3
Lifting & transport, risk reduction measures, maintenance and repair	
Technical description / drawings	4 - 5
Base element, top element, standard spindle	
Assembly / installation	6 - 12
Extension assembly, installation in ready-dug trench, push-and-dig method, lowering the system, sing protection rails, installing additional shoring sections, pipe laying	
Extraction	12 - 13
Instructions for extraction	





► Operating Manual

General instructions

The shoring system must be installed without gaps and sit snugly in the soil. Maximum loads must not be exceeded. Individual sections may only be fitted if the open ends are properly secured.

The current versions of the following rules and regulations must be adhered to:

- Regulations of the BG-Fachausschuss Tiefbau (technical committee civil and underground engineering)
- DIN 4124 Excavations and trenches
- DIN EN 13331 Parts 1 & 2 Trench lining systems
- Occupational health and safety regulations
- Accident prevention regulations / occupational safety regulations

Our system components are GS safety certified. The instructions in this manual must be followed when installing our shoring systems.

Lifting and transport

- Chains for lifting the shoring box may only be attached at the designated lifting and handling points.
- The lifting equipment must be suitable for the load to be lifted.
- For safety reasons, only lifting hooks with a safety catch may be used.
- The permitted tensile forces must be strictly adhered to.
- Transport should take place as close to the ground as possible, unnecessary swinging movements are to be avoided.
- While the load is being lifted, personnel or bystanders are not permitted to enter the slewing range of the lifting equipment or move under suspended loads.
- Check for overhead wires!
- Operator and banksperson must maintain eye contact throughout the operation.

Risk reduction measures

- The excavation site must be sufficiently secured and marked.
- Traffic flow next to the site must be controlled by additional safety personnel if required.
- All personnel must wear personal protective equipment (safety helmet / safety shoes/boots / gloves).
- Potential instabilities due to wind must be taken into consideration during assembly and installation of the shoring box.
- The shoring components should ideally be stored flat on a level and firm surface.
- Even greater care must be taken when pre-assembled components need to be stored on sloped ground.

Maintenance and repair

- Operability of all system components must be checked before every use.
- Faulty or warped components must not be used.
- Slight damage may be repaired by a competent user after consulting with TWF. Otherwise, the service department in our manufacturing plant is available to help.
- Only original TWF parts may be used to repair the systems.

Depending on frequency and intensity of use, the components should be painted with anti-corrosion paint every two years.



► TWF - XL-BOX Type 690

■ XL-BOX Type 690

- Cost-efficient construction processes with the highest degree of safety and high pipe clearance at trench depths up to 5,80 m.
- Installation by **lower and cut method** in unstable soils
- Mobile- or crawler excavator: 18 - 24 t
with top element: 22 - 30 t
- Maximum trench depth: 5,80 m
- Trench width: 0,97 - 6,05 m
- Pipe clearance height: 2,06 m

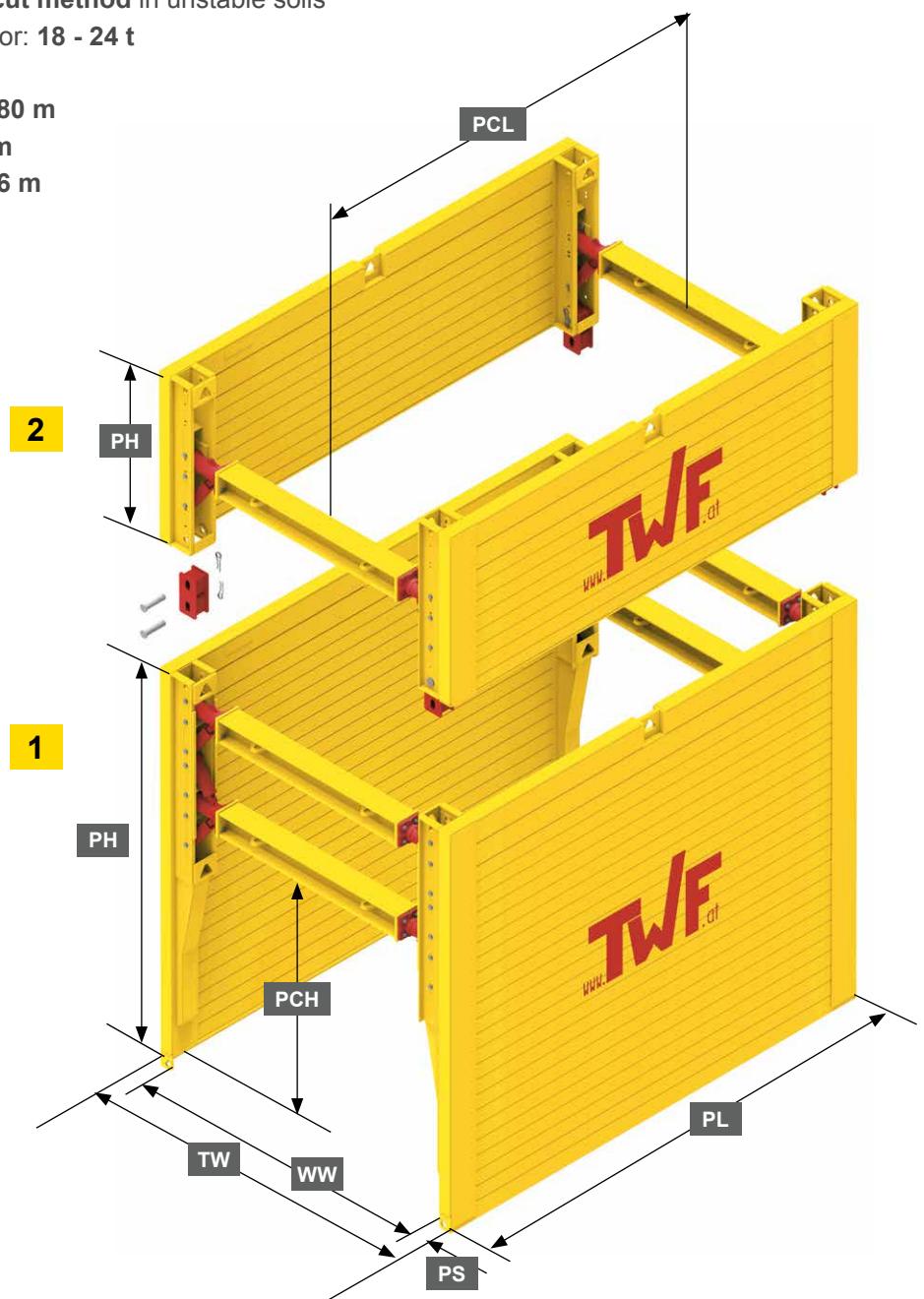

1	Base element
2	Top element

PH	Panel height
TW	Trench width
WW	Working width
PT	Panel thickness
PCH	Pipe clearance height
PL	Panel length
PCL	Pipe clearance length



► Operating Manual

Element	Panel length PL (m)	Panel height PH (m)	Panel thickness PT (mm)	PC-length PCL (m)	PC-height PCH (m)	Char. system resistance R_k (kN/m ²)	Weight c/w spindle (kg/box)
1	2,00	3,15	100	1,60	2,06	40	2204
2		1,32					1102
1	2,50	3,15	100	2,10	2,06	40	2470
2		1,32					1248
1	2,90	3,15	100	2,50	2,06	40	2682
2		1,32					1364
1	3,40	3,15	100	3,00	2,06	40	2948
2		1,32					1508
1	3,70	3,15	100	3,30	2,06	40	3108
2		1,32					1596

► Other lengths on request!

■ Strut Extensions HEB 180

- Strut extension lengths:
0,275 | 0,550 | 1,100 | 1,650 | 2,200 m
Customised lengths on request

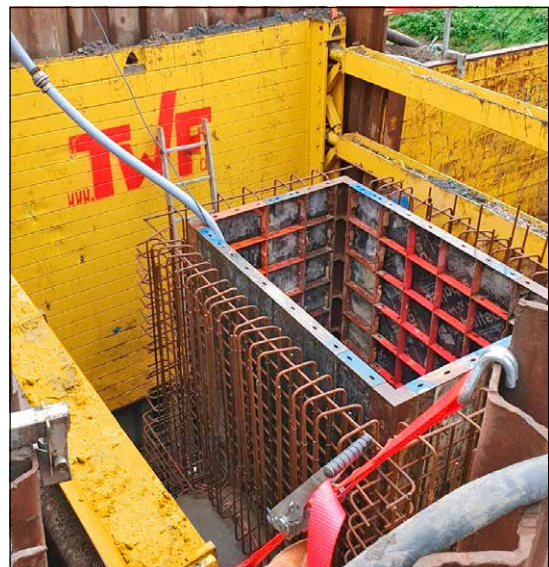
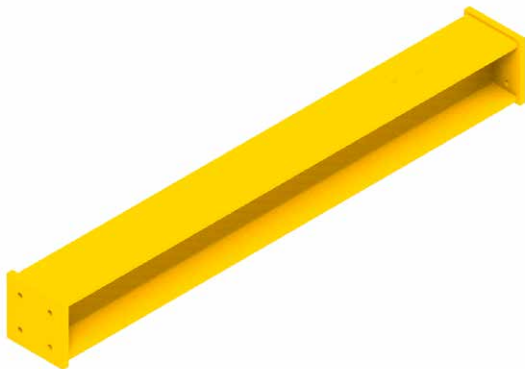

09-2023



► TWF - XL-BOX Type 690

■ Assembly instructions

Installing the strut extensions

- Attach two shoring boxes securely to each other, e.g. using screw clamps. The two plates of one box may only be detached by loosening the strut connector bolts M 16 x 55 once the unsecured plate is attached securely to a lifting device using suitable chains and hooks.
- The free plate must now be set down carefully, flat on level ground with the strut connectors uppermost, and each strut connector attached to the selected and pre-assembled extension using the appropriate nuts and bolts (connector type extensions/struts: 4 x bolt M 16 x 55-8.8-DIN 933 VZ and nut M 16-8-DIN 934 VZ).
- The plate with the fitted extensions is then lifted into place against the second, upright and secured plate using the appropriate lifting equipment in such a way that the extensions can be attached using the prescribed number of bolts M 16 x 55-8.8-DIN 933 and nuts M 16- 8-DIN 934 on the other side. Only normal forces are transmitted.
- People must not enter trenches over 1.25 m deep that have not been sloped or secured using shoring equipment.

It also not permitted to stay in the danger zone, e.g. near the edge of the trench, for any length of time or work there using heavy equipment. All relevant DIN, EN, UVV and BGBau (statutory accident insurance institution for the construction sector and related services in Germany) guidelines must be adhered to.

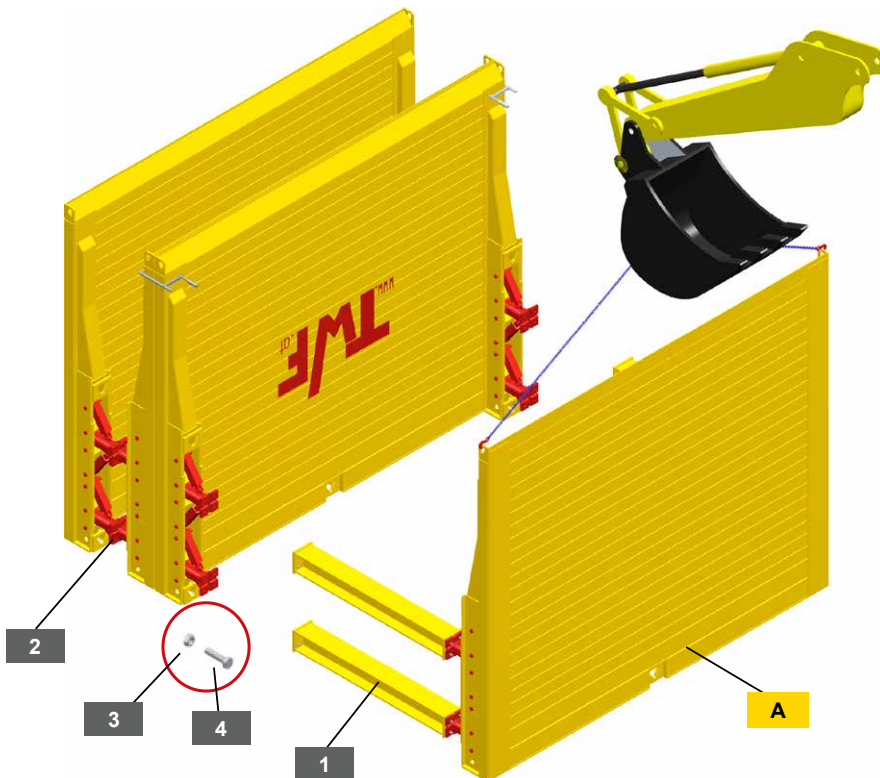

A	Base plate
1	Extension
2	Strut
3	Bolt M 16 x 55-8.8-DIN 933
4	Nut M 16- 8-DIN 934



► Operating Manual

■ Installation instructions

Placement in the ready-dug trench

- The shoring box is placed in the trench that has been excavated to its final depth.

This method is only permissible if the following conditions are met:

- Temporarily stable soil
- Vertical trench walls
- Outside the area of influence of buildings or other structures
- Outside the area of influence of traffic areas and lines/pipes
- Acceptable anticipated degree of settlement

- The ground is considered to be temporarily stable if no significant amounts of soil come loose and fall into the trench between the start of the excavation and installation of the shoring box.
- Where the trench depth exceeds the height of the base plate, base and top elements must be assembled outside of the trench and lowered into the trench as one unit if this method is used.
- Base and top element must be attached to one another using stanchions and pins, secured by arc clips.
- The complete box consisting of base and top element is to be placed in the completely dug trench using suitable lifting gear and slings.

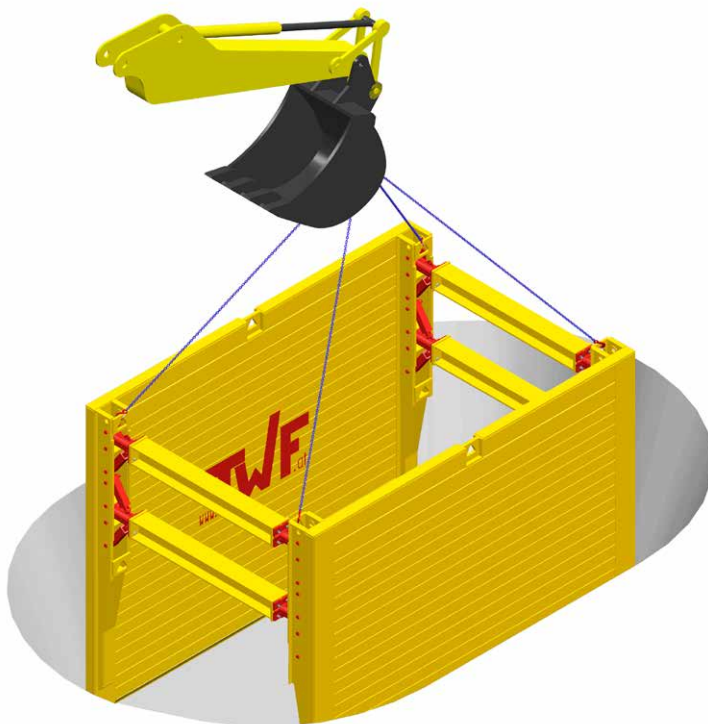

- The excavation length must be kept to the length of one box.
- The chains must be attached at a minimum of four of the designated lifting points.
- Any voids between the outside of the box and the trench wall must be backfilled and compacted.

► TWF - XL-BOX Type 690

Push-and-dig method

- Using the push-and-dig method, shoring systems or parts thereof are pushed vertically into the ground.
- Before using the respective shoring system, its struts must be adjusted to create a bigger distance between plates at their lower ends than at the upper ends by turning the spindles. This "A-shape" is achieved by turning out the lower spindles approximately 20 mm further per metre of box height than the upper spindles.
- The pre-dug trench must be no wider than 1.25 m and no longer than one shoring box length. Pre-excavation depth generally depends on the type of soil and is subject to the relevant safety regulations.
- Attach the chains at the four designated lifting points and place the base element with the spindles adjusted according to trench width into the pre-dug trench, align, and push down.
- Any voids between the outside of the box and the soil must be backfilled and compacted.

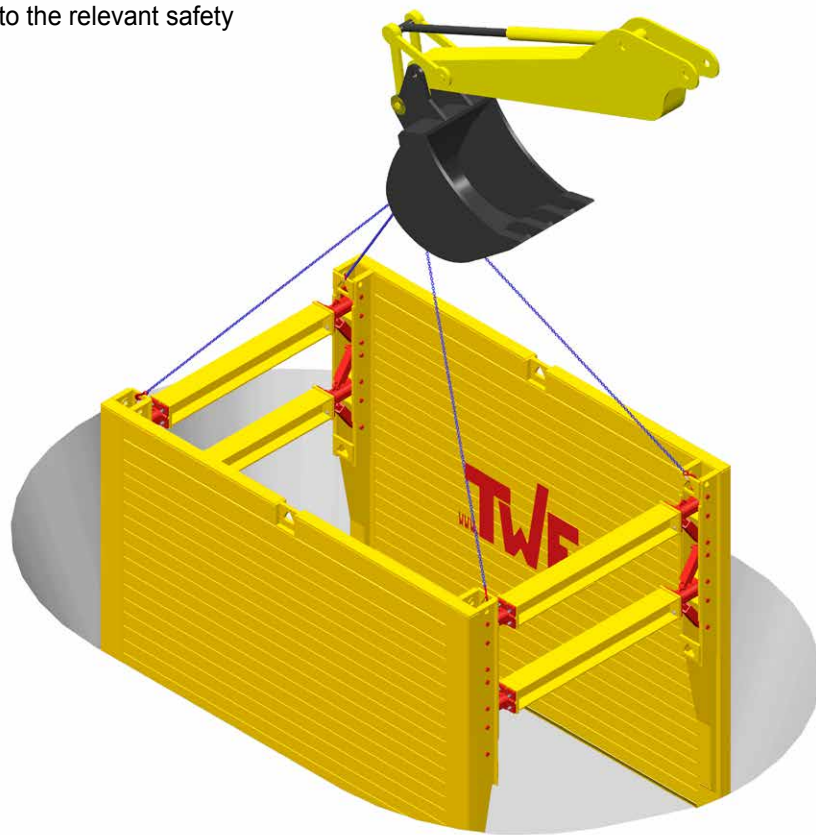



► Operating Manual

Pushing down the shoring system

- The shoring plates must be pushed and not driven down. For safety reasons, pushing down on the struts is not permitted.
- During this phase it is not permitted to enter the trench.
- Dig down approximately another 0.50 m and push down the box, alternating between plate halves. The smaller the increments the box is pushed down by, the better for the shoring system. Do not push down more than 0.50 m at one side and limit the inclination of the struts to +/-8 degrees.
- In order to avoid damage to the plates, do not use them as "chisels". Potential solid obstructions (e.g. unnatural fills, rock) must be cleared manually. To avoid settings at the surface it must be ensured that any voids behind the plates are backfilled with soil.

Using protection rails

- To protect the shoring plates from damage and to ensure a long useful life of the systems, we recommend using protection rails.



► TWF - XL-BOX Type 690

Fitting top extension plates

- For deeper trenches, top extension elements must be used. Lift the pre-assembled top element with struts set to match the trench width by the four lifting points, align with the base element, set down and connect the top and base element using stanchions and pins.
- The shoring system is then further inserted into the ground by alternating between excavating further and pushing down the shoring plates. For trenches with a depth of more than 2.00 m, the top edge of the shoring box must remain 100 mm above ground level.
- Base and top element must be attached to one another using stanchions, pins and arc clips.
- The system is to be assembled using suitable lifting gear and slings. The slings are to be attached at a minimum of four of the designated lifting points.

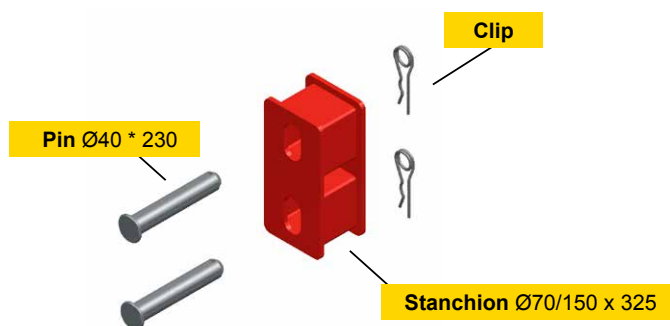
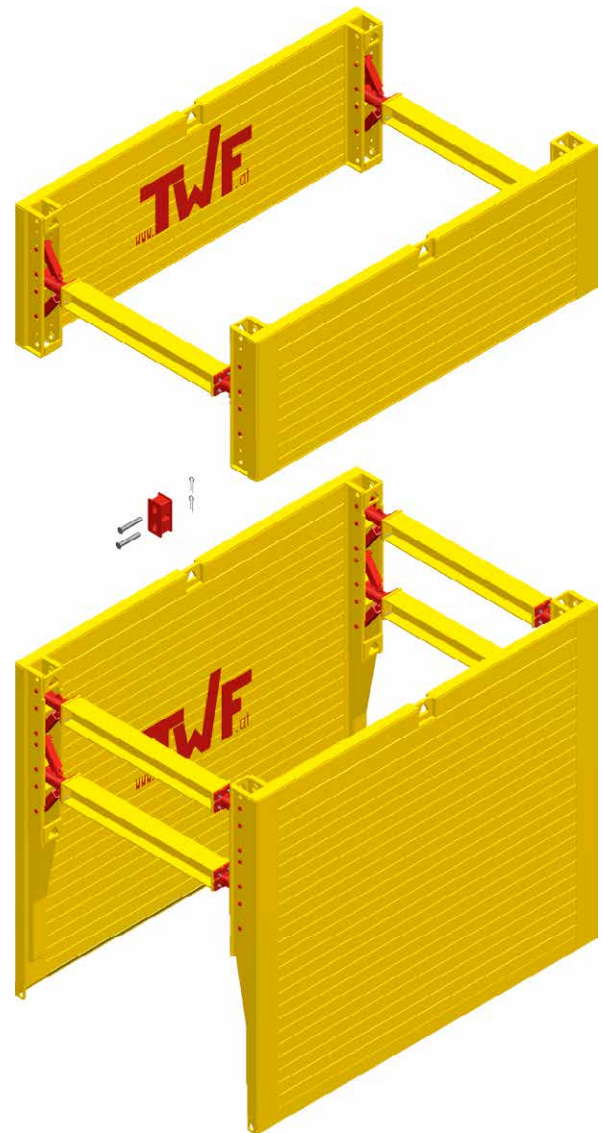



► Operating Manual

Inserting further shoring boxes

- Once a shoring box has been inserted to full depth, installation of the next segment can commence.
- Follow the same installation sequence as outlined above.
- Once the shoring elements have been installed, pipe laying can commence in the secured section of the trench.
- There must be no gaps between boxes. Sections of the trench that cannot be secured using shoring units, e.g. due to lines crossing the trench, must be shored in a different way.

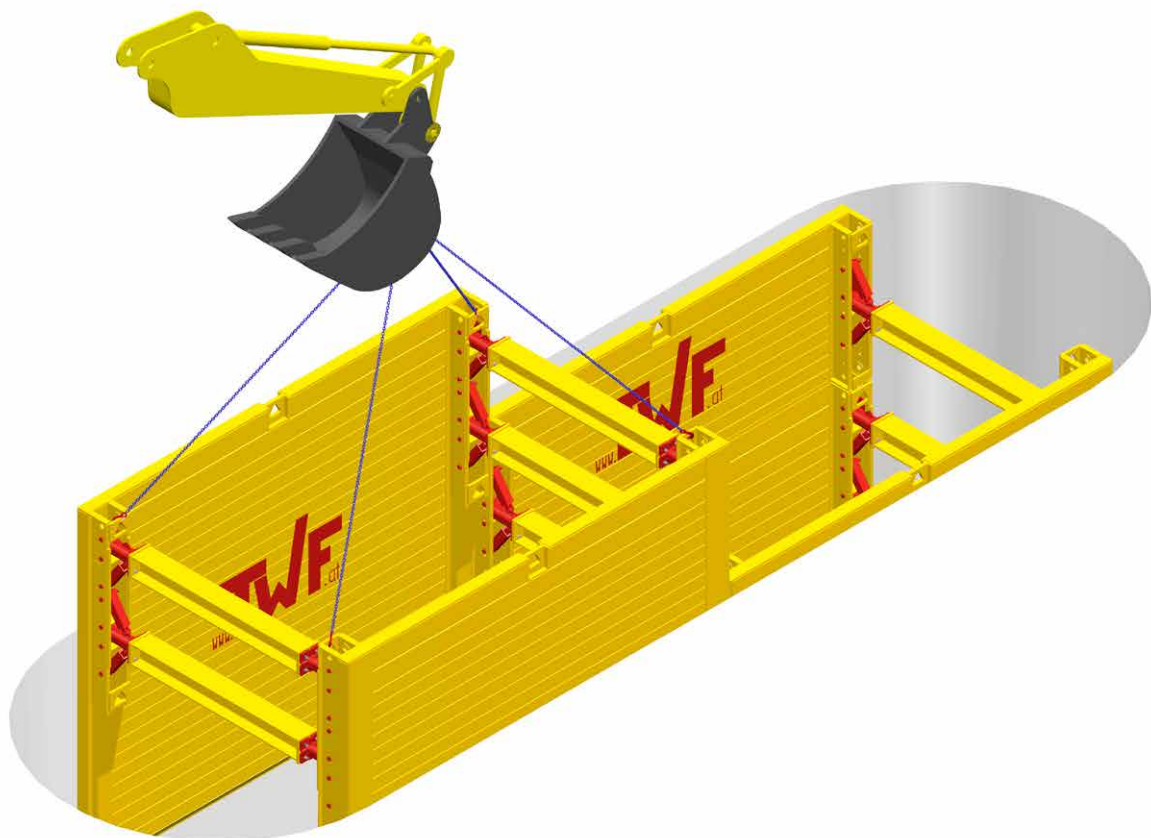

► TWF - XL-BOX Type 690

Pipe laying

- After the shoring system has been installed according to the instructions above, pipe laying work can commence in line with documentation provided by the pipe manufacturer.

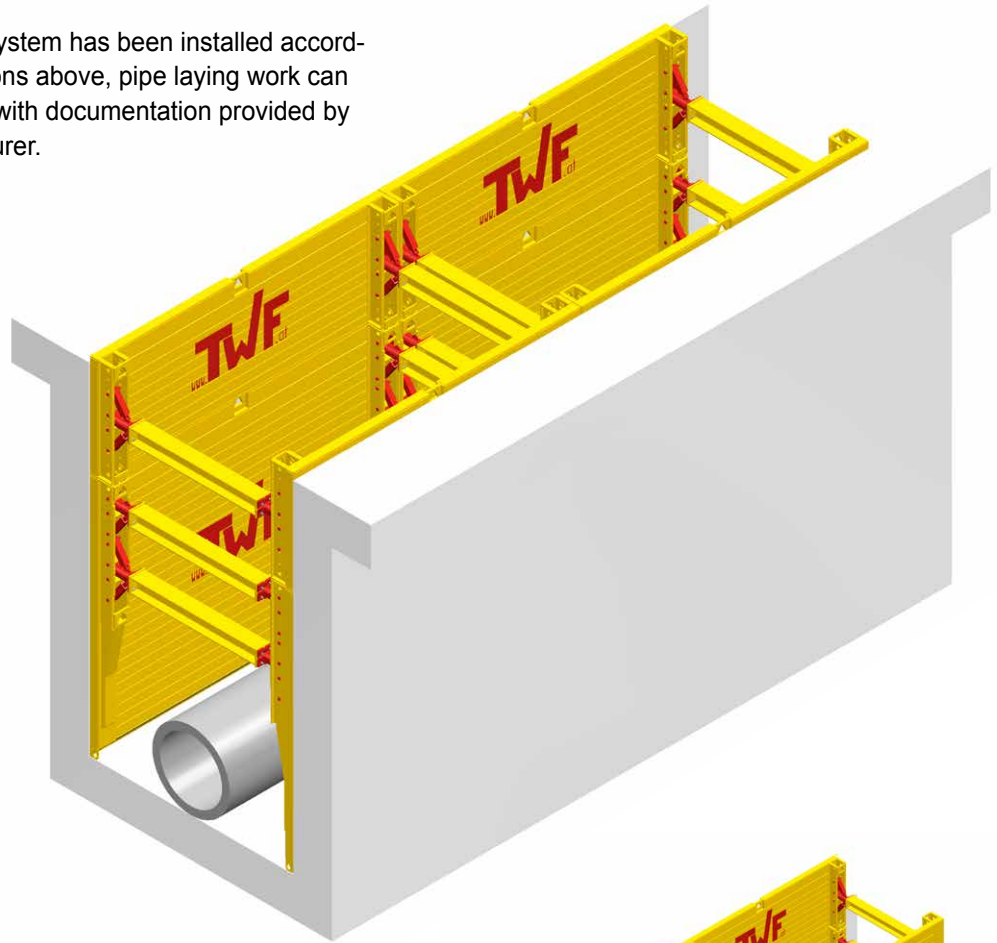

Extraction

- When pipe laying is complete, the shoring system can be extracted.
- Depending on the ability to compact, backfill up to 0.50 m high. Pull up the shoring box by a distance equal to the filling height. Then compact the filling material.

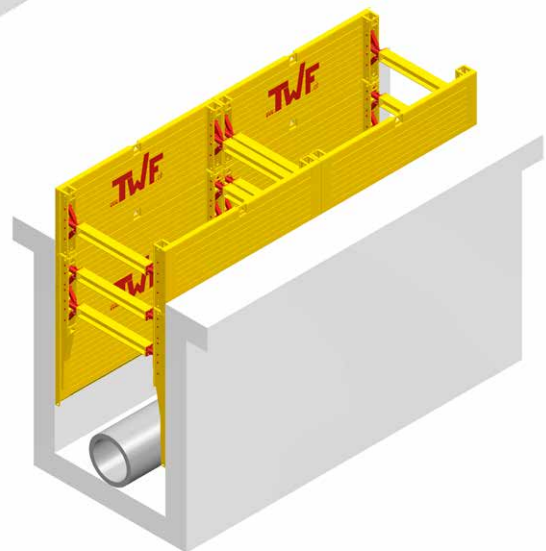



► Operating Manual

- The smaller the increments the box is pulled up by, the better for the shoring system. Do not pull up by more than 0.50 m on one side at a time and limit the inclination of the struts to +/-8 degrees.
- Keep repeating the process until the shoring box can be lifted out of the ground in line with all relevant safety regulations.

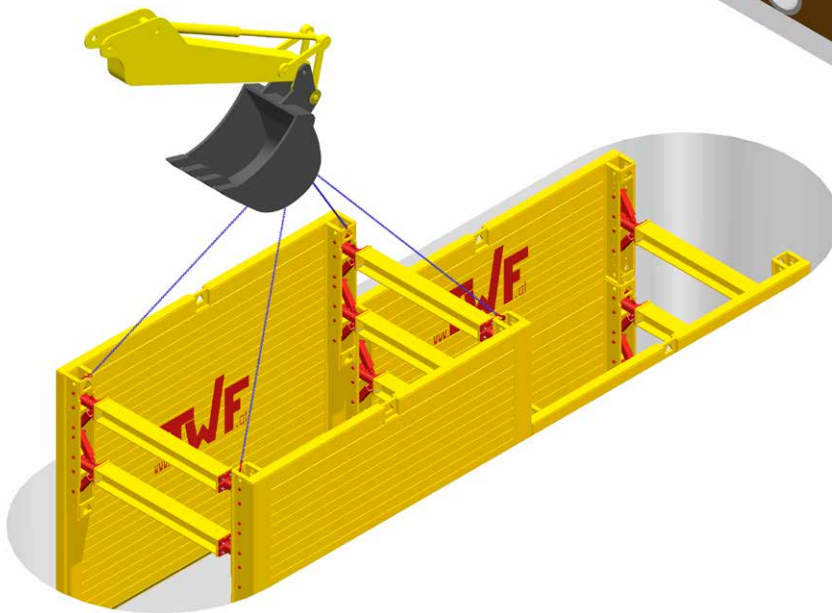
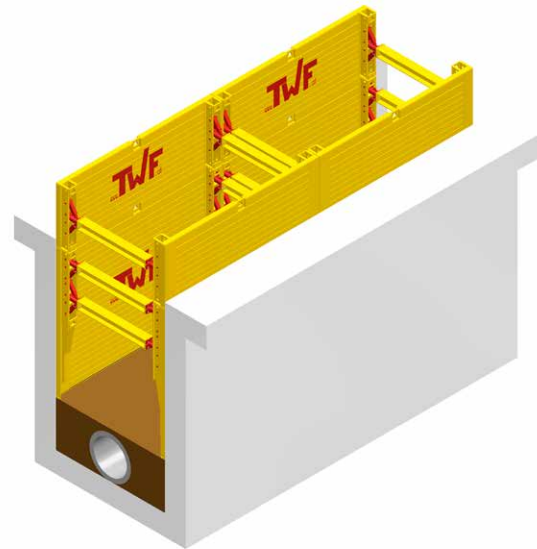

- The shoring box must only be pulled up using the designated lifting points. It is not permitted to pull it up at the struts!
- Please note that it is not permitted to enter the risk area during installation as well as extraction of the system.
- Do not pull the system up on just one side in order to avoid putting excessive strain on the shoring plates. During extraction, the box must always be pulled in a vertical direction. Pulling the box up at a slant damages the edge profiles.
- Slings must be attached to at least two designated lifting/handling points of a plate.

TWF TIEFBAUTECHNIK

Sales | Rental | Leasing



XL-BOX TYPE 690

TWF Tiefbautechnik GmbH

Düsseldorfer Straße 2, D-52525 Heinsberg, Germany

T: +49 2452 15678-0

F: +49 2452 15678-19

office@twf-tiefbautechnik.de

www.twf-tiefbautechnik.de

TWF International GmbH

Klingerstraße 8, A-1230 Wien

T: +43 1 8653333

F: +43 1 8653333-33

office@twf.at

www.twf.at

OPERATING MANUAL